

# Aerostar HEGA Filters - Series 3000

	Single Header			
Nominal Dimensions	24x24x12	20x24x12	20x20x12	12x24x12
Height, H (inches)	23.38	19.38	19.38	11.38
Width, W (inches)	23.38	23.38	19.38	23.38
Depth, D (inches)	11.50			
Media Area (sq ft)	108	89	72	48
Pressure Drop ("WG)	0.40			
at Flow Rate (cfm)	2000	1667	1389	1000
Carbon Weight (pounds)	11.0	9.1	7.4	4.9

Media Selection	24x24x12	20x24x12	20x20x12	12x24x12
147: Amonia / Amines	15024	15025	TBD	15026
651: Diesel Exhaust	19321	76612	76613W	19319
653: VOC's / Ozone	17982	17983	300332	17984
875: Acid Gas	17083	17414	74000	16505

**Frame Material:** Injection-molded High Impact Polystyrene (HIPS)  
**Adhesive:** Media bonded with a durable, flexible, low off-gassing sealant  
**Temperature:** 120 F Continuous / 130 F Intermittent  
**Installation:** Install with pleats vertical when possible  
 Install 10' from heat source  
**Naming:** Series 3651 = Series 3000 with 651 Media  
**Note:** Other sizes available

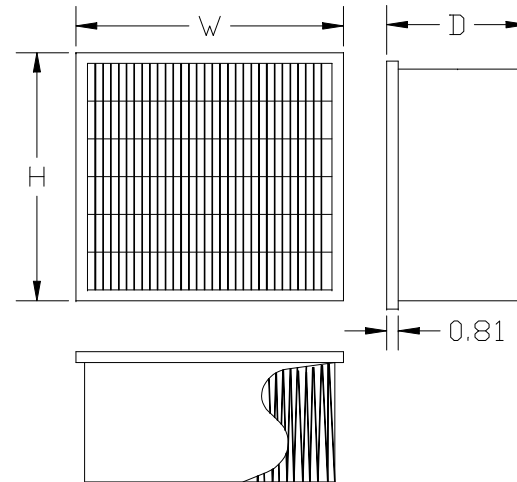

Filtration Group  
 912 E. Washington Street  
 Joliet, Illinois 60433  
 815-726-4600

TOLERANCES UNLESS OTHERWISE SPECIFIED: .XXX = ± 0.005 .XX = ± 0.015 ANGLES = ± 1/2 DEGREE REMOVE ALL SHARP EDGES	Drawn	Date	Description: <b>Aerostar HEGA Filters</b> <b>Series 3000</b>
	<b>PJW</b>	<b>3/2/2007</b>	
	Approved		Drawing no.    Rev. <b>99-35050    B</b>
	<b>PJW</b>	<b>3/2/2007</b>	
Sheet	1 of 1		