

FILTRATION GROUP

SEAL FRAME



- Available in 16 gauge galvanized steel or 304L stainless steel
- Can be used individually or in multiple banks
- Easy to assemble
- Accommodates a wide range of filter types and depths



DESCRIPTION

The Aerostar Seal Frame is a holding frame that is used to hold individual filters, or multiple banks of 1" up to 11 1/2" filters. Clips are required to hold the filters in place. The Seal Frame has pre-punched holes for easy assembly and proper alignment. Pop rivets or nuts/bolts are used to assemble frame and all sides should be caulked to prevent air by-pass. Gaskets should be used on the frame or the filters. The Seal Frame can be used for new installations or upgrades of existing systems. Constructed in 16-gauge galvanized steel, this durable framing system can be assembled in the field, into built up filter banks.

BENEFITS

The versatility of the Aerostar Seal Frame makes it ideal for many applications. Installing filters is easy with the use of clips. Several different configurations are available, for use with various duct sizes and capacity requirements.

APPLICATIONS

The Aerostar Seal Frame can replace any existing filter framing system. It is designed for use with 1" filters up to 11 1/2" filters, with or without pre-filters. This frame can be used in any application where there is a need for air filtration such as schools, office buildings, hospitals and industrial applications.



ENGINEERING SPECIFICATIONS

The filter holding frames shall be Aerostar Seal Frame, manufactured by Filtration Group Inc. Holding frames shall be 3" deep and constructed in 16-gauge galvanized steel. For larger configurations vertical supports shall be used to add strength. Holding frames shall be pre-punched to assure proper alignment and easy assembly in the field.

All corners shall be continuously welded and ground smooth. Filters shall be held in place by the use of clips. The frame shall allow for the use of pre-filter without disturbing the final filter. Gaskets in the frame or on the filter shall be used to prevent any leakage. The gasket shall be oil and moisture resistant high density PVC foam gasket.

OPTIONS

- 304L Stainless steel
- Gasket
- Clips

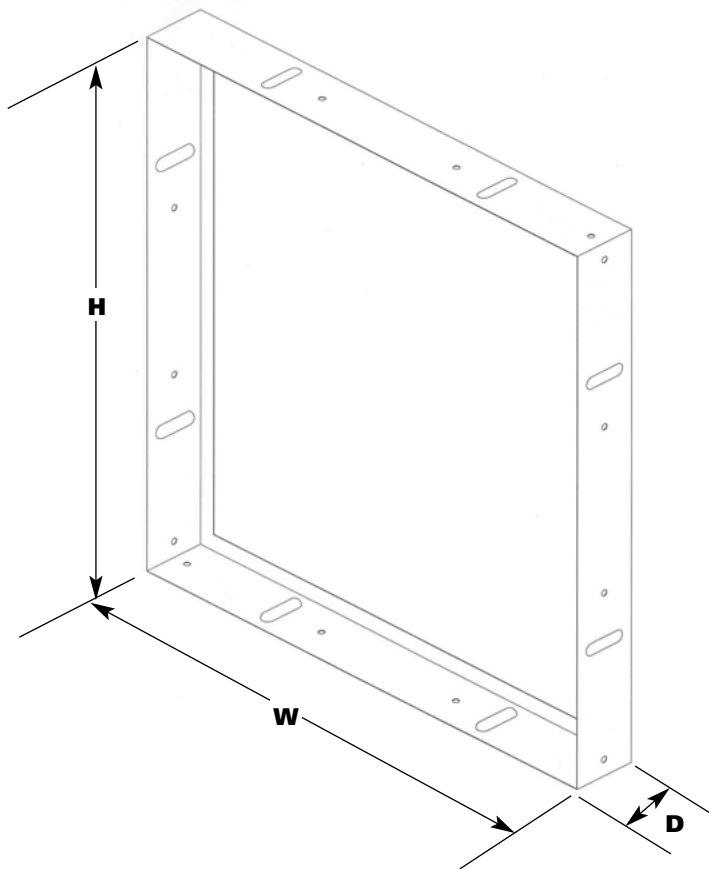

DISTRIBUTED BY

© FGI 01/08

